

cramer<sup>®</sup>

## **Cramer Lab Chairs GSA Price List**

**Effective January 1, 2026**



# Table of Contents

## HELIX

---



**Helix – p.10**  
The future of modern lab and caregiver seating

## LOOP

---



**Loop – p.12**  
Simply technical seating

## FUSION r+

---



**Fusion r+ – p.14**  
Versatile, Lab-Grade Performance with r+ covering

## FUSION ROUND STOOL r+

---



**Fusion Round Stool r+ – p.16**  
Fusion Build, with r+ covering



## Contractor Name & Ordering Address

Cramer LLC  
1523 Grand Boulevard, Kansas City, MO 64108  
Phone: 1.800.366.6700 | Fax: 1.800.607.2821

## GSA Contract Specifications

Contract: GS-27F-012GA | Business Size: Small  
TIN: 27-0988375 | Cage Code: 6PHV8  
Contract Date: Feb 1, 2017 - Jan 31, 2027

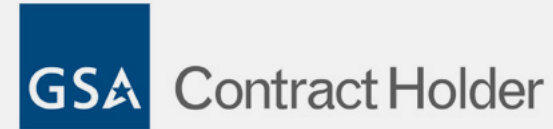

**Restocking/Returns:** 20% restocking charge. No returns accepted without written authorization from Cramer Corporation. Cancellations: Client will not be charged for any cancellation if order is canceled in writing to Cramer LLC, Corporation prior to start of production or purchase of special fabric. If production is in process, client will only be charged costs incurred that cannot be recovered within a reasonable length of time (6 months).

### 1a. Awarded Special Item Numbers

33721 Multipurpose Seating

### 1b. Lowest price model per SIN

33721 Model LPDU@ \$489.50

### 2. Maximum Order Limitation

\$200,000.00

### 3. Minimum Order

N/A

### 4. Geographic Coverage

48 Contiguous States and the District of Columbia

### 5. Production Point

Holland, MI

### 6. Discount from List Price

45% off list price

### 7. Quantity Discounts

N/A

### 8. Prompt Payment Discount

1%-20 Net - 30 days.

### 9a. Government Purchase Card is accepted at or below the micro-purchase threshold.

### 9b. Government Purchase Card is accepted at or above the micro-purchase threshold. (Maximum \$25,000.00, no discount)

### 10. All items made in the U. S. A.

### 11a. Time of Delivery

40 days ARO

### 11b. Expedited Delivery

Shipment made 5 business days after receipt of order

### 11c. Overnight and 2nd day delivery

N/A

### 11d. Urgent Requirements

N/A

### 12. FOB

Destination

### 13a. Ordering Address

CRAMER LLC  
1523 Grand Boulevard,  
Kansas City, MO 64108  
Phone: 1.800.366.6700 | Fax: 1.800.607.2821

### 13b. Ordering Procedures

For supplies and services, the ordering procedures, information on Blanket Purchase Agreements (BPA's), and a sample BPA can be at the GSA/FSS Schedule homepage.

### 14. Payment Address

Same as #13a above.

### 15. Warranty

Standard Commercial Warranty.

### 16. Export Packing quoted upon request call customer service.

### 17. Terms & Conditions of Government Commercial Credit Card Acceptance: No Discount Allowed.

### 18. Terms & Conditions of rental, maintenance and repair

N/A

### 19. Terms & conditions of installation:

N/A

### 20. Terms & conditions of repair parts:

N/A

### 21. List of service and distribution points:

N/A

### 22. List of participating dealers:

See attached, call customer service for any recent updates

### 23. Preventative Maintenance:

Instructions supplied with product

### 24. Environmental attributes:

SCS Gold Certified & LEED contributions available on request

### 25. Data Universal Number System (DUNS) number: 00-713-1204

### 26. Cramer LLC is registered in the Central Contractor Registration (CCR) database)



Technical environments - laboratories, medical offices, hospitals and research facilities - demand seating solutions that meet rigorous technical standards and provide all-day support and comfort. Cramer engineers the highest quality lab-grade seating to address these sensitive environments while providing performance and peace of mind.

CLINICAL

LABORATORY

TECHNICAL

INDUSTRIAL

## WHEN YOU CHOOSE CRAMER SEATING, YOU CAN EXPECT:

### BUILT-TO-ORDER

Each chair is made to order, designed to your exact specifications.

### SUPERIOR WARRANTY

We invite you to compare. We think you'll agree - our 12-year three-shift warranty is simply the best in the industry.

### CUSTOMER CARE

Our team is always available to offer information, assistance or advice. Call us. You'll be glad you did.



### Authorized Dealers:

Cramer works with authorized dealers to ensure the very best service and information. Call Cramer for an authorized dealer in your area. Possession of this price list does not constitute authority to sell products contained in this price list.

### To Order:

Please include the following with every order: purchase order number, quantity, model number, caster, upholstery and option code selection. To help us avoid errors, Cramer requires all purchase orders to be emailed, faxed or mailed. Your order is not considered binding until it has been accepted and acknowledged by Cramer.

Email: [orders@cramerinc.com](mailto:orders@cramerinc.com)

Fax: 800.607.2821

Mail: 1523 Grand Blvd., Kansas City, MO 64108

### Specials:

Configurations not shown are subject to a \$50 net specials charge and may require additional time.

### Additions or Changes:

Orders placed for 5-day lead-times are produced immediately and no changes or cancellations can be made. On extended lead-time orders, a written request must be submitted to add, or make changes to an order. This may affect your shipping date. Charges for changes or additions may apply as follows:

- 20 or more working days before shipping date  
No Charge
- 15 - 19 working days before shipping date  
20% of Order Value
- 5 - 15 working days before shipping date  
70% of Order Value
- < 5 working days before shipping date  
Not Available

## SHIPPING

### Shipping Charges:

List prices include freight to any point within the contiguous 48 states. For orders shipped to locations outside of the continental US freight is included only to the port of embarkation. Most products are shipped knocked-down. Easy assembly - no tools required.

### Specialty Shipping:

For an additional charge, you can request fully assembled product palletted or inside on-site delivery. Request a quote from: [orders@cramerinc.com](mailto:orders@cramerinc.com)

### Claims for Damage During Shipping:

Cramer uses freight carrier approved packaging materials and carefully handles all products. When your order arrives, please examine each item and note damages or shortages on your delivery receipt. If the shipping box is damaged, note this also. If you discover damage that was concealed, you must report it to the freight carrier and Cramer within 5 business days of delivery.

### Returns:

All products are built to order. Products may be returned only with Cramer approval. You must put your RA (return authorization) number on the outside of any returned package. Returned goods will be subject to a restocking charge and Cramer reserves the right to deny credit for any damages.

### Standard Terms of Sale:

1% 10 days or net 30 days from the date of invoice. Credit approval required. Orders may require a down payment.

## PRODUCT DESIGN

Cramer reserves the right to make changes in design and construction or discontinue products without prior notice. All dimensions are to be considered approximate. Weights shown are chair alone and do not include optional accessories.

Prices are subject to change without notice.

## CRAMER QUALITY ASSURANCE

Helix, Fusion and Rhino Basic lines of Cramer seating products meets or exceeds specifications, standards and test requirements for ANSI/BIFMA X5.1-2017. NSTA shipping requirements and California Technical Bulletins 117.

# Helix



## Meet Helix, the future of modern lab and caregiver seating.

Its patent-pending Frameless Back™ hugs the user, providing total support and unmatched freedom of motion. Its i+™ Polyurethane seamless seat and back cushions are perfect for clean environments, and the organic form and optional color accents bring a modern sensibility to progressive healthcare and lab facilities. Whether you twist, relax, focus or reach - Helix is there to support you.

### FEATURES

- Patent-pending Frameless Back™ adapts organically to the user, providing exceptional freedom of motion and comfort
- Intuitive one-touch height adjustment
- Seamless i+™ Polyurethane cushions resist contaminants and will withstand hospital cleaning agents
- Streamlined form minimizes the visual impact and doesn't interrupt sightlines
- Meets BIFMA Healthcare Furniture Cleanability Guidelines HCF 8.1
- ISO-Class 4 cleanroom rated
- 300lb weight capacity
- SCS Indoor Advantage Gold Certification and may help contribute toward LEED certification

### CONSTRUCTION

- i+™ Polyurethane seat and back
- Advanced thermoplastic elastomer flexing upright
- Heavy-duty formed steel mechanism
- Resilient glass fiber support spring
- 25" durable nylon base
- Class 4 pneumatic cylinder

### OPTIONS

- High-performance twist-lock flat surface steel 20" black footring. Footring is only available on desk-to-counter and high-height
- Casters: multi-surface dual wheel is standard. Non-rolling glides and breaking casters are also available
- Desk, desk-to-counter, and high-height
- Available in five colors: Slate (dark grey), Stone (light grey), Citrine (yellow), Aquamarine (blue), Coral
- Fixed arm option available



# Helix

cramer

### PRICING

CHAIR HEIGHT	MODEL NUMBER	LIST PRICE
Desk	HXDU	\$715.00
Desk-to-Counter	HXLU	\$838.75
High	HXHU	\$811.25

### DIMENSIONS

SEAT DIMENSIONS	WIDTH (X) DEPTH	18.50 (X) 16.75 IN
SEAT HEIGHT	MIN-MAX	
	DESK	16.00 IN - 21.00 IN
	DESK TO COUNTER	17.25 IN - 24.50 IN
	HIGH	21.50 IN - 31.50 IN
BACK DIMENSIONS	WIDTH (X) HEIGHT	18.00 IN (X) 17.25 IN
BASE DIMENSIONS	DIAMETER	25 IN
ARMPAD HEIGHT ABOVE SEAT	FIXED	8.75 IN
DISTANCE BETWEEN ARMPADS	FIXED	20.75 IN
WEIGHT	DESK	26 LBS
	DESK TO COUNTER	33 LBS
	HIGH	33 LBS
	ARMS	4 LBS

### HOW TO CHOOSE THE MODEL

WORK SURFACE HEIGHT	CHAIR HEIGHT
29 - 32 IN	Desk
30 - 37 IN	Desk-to-Counter
33 - 42 IN	High

### OPTIONS

ORDER CODE	CATEGORY	LIST PRICE
<b>COLORS</b>		
101	slate.....	
102	aquamarine.....	
103	stone.....	
104	coral.....	
105	citrine.....	
<b>CASTERS</b>		
2	multi-surface dual wheel.....	standard**
3	non-rolling glide.....	n/c
9	weight activated breaks when seated.....	\$88.00
<b>ARMS</b>		
A	fixed arms.....	\$82.50

\*\* Standard casters and footring included unless different options are requested.



### HOW TO ORDER

MODEL NUMBER	COLOR CODE	AVAILABLE OPTIONS CODE
<input type="text"/>	<input type="text"/>	<input type="text"/>

# Loop



**Loop: Strength meets simplicity in laboratory seating**  
 Introducing Loop. Our newest lab chair that blends durability, simplicity and style. Loop features an ergonomically sculpted, chemical-resistant polypropylene back and a durable polyurethane seat for an easy to clean chair with lasting comfort and support. Designed for aesthetics, durability, and versatility—Loop's defining features are the right fit for labs.

## FEATURES

- Loop's continuous loop steel frame is strong, durable, and lightweight
- Soft edges buffer damage-inflicting impact to the chair and surrounding environment
- Minimal joint hygienic design for easy cleaning and disinfection
- Organic chair shape receives and supports the user's body
- Chemically-resistant polypropylene back for ultimate cleanability
- Color palette complements any lab environment

## CONSTRUCTION

- 14-gauge powder-coated steel frame
- i+™ Polyurethane seat
- 25" durable nylon base
- Polypropylene back
- Field-replaceable seat cushion
- Glass-filled nylon seat pan



# Loop

cramer

## PRICING

CHAIR HEIGHT	MODEL NUMBER	LIST PRICE
Desk	LPDU	\$489.50
Desk-to-Counter	LPLU	\$544.50
High	LPHU	\$533.50

## DIMENSIONS

SEAT DIMENSIONS	WIDTH (X) DEPTH	18.00 (X) 17.00 IN
SEAT HEIGHT	MIN-MAX	
	DESK	14.00 (X) 19.50 IN
	DESK TO COUNTER	15.50 (X) 23.00 IN
	HIGH	19.75 (X) 30.00 IN
BACK DIMENSIONS	WIDTH (X) HEIGHT	14.00 (X) 8.00 IN
MAX OVERALL DIMENSIONS	DIAMETER	25.00 (X) 25.75 IN
WEIGHT	DESK	18 LBS
	DESK TO COUNTER	25 LBS
	HIGH	25 LBS

## HOW TO CHOOSE THE MODEL

CHAIR HEIGHT	WORK SURFACE HEIGHT
Desk	29 - 32 IN
Desk-to-Counter	30 - 37 IN
High	33 - 42 IN

## OPTIONS

ORDER CODE	CATEGORY	LIST PRICE
<b>COLORS</b>		
100	flame .....	
200	sky .....	
300	iron .....	
400	stone .....	
500	white.....	

<b>CASTERS</b>		
2	multi-surface dual wheel .....	standard**
3	non-rolling glide .....	n/c
9	weight activated breaks when seated .....	\$88.00

\*\* Standard casters and footing included unless different options are requested.



## HOW TO ORDER

MODEL NUMBER	COLOR CODE	AVAILABLE OPTIONS CODE
<input type="text"/>	<input type="text"/>	<input type="text"/>

# Fusion



The Fusion series is our most flexible line with dozens of configurable options and available with r+ Technology - our patented polyurethane cover system. This versatility makes Fusion our best-selling line that can fill a variety of roles in both lab and technical environments.



## FEATURES

- Heavy-duty steel seat for multi-shift durability
- Contoured molded seat with waterfall edge ensures 24-hour comfort
- Dynamic range of adjustments support the full range of seated postures from active forward-leaning to recline
- High performance twist-lock footing with 20" diameter (on desk-to-counter and high heights)
- Supports up to 350 lbs
- 12-Year, Three-Shift Warranty
- SCS Indoor Advantage Gold Certification and may help contribute toward LEED certification
- R+ meets BIFMA Healthcare Furniture Cleanability Guidelines HCF 8.1
- ISO Class 5 Cleanroom

## CONSTRUCTION

- 26.75" fiberglass-reinforced nylon base
- 16-gauge steel seat pan
- Integrated steel arm structure with metal-to-metal connections eliminates points of failure
- High resiliency 3.5" thick seat foam
- Heat-bonded powder coat finish

## OPTIONS

- Arms: an adjustable arm option or a fully articulating arm option

- Casters: multi-surface dual wheel is standard. A variety of other casters are also available
- High-performance twist-lock footings: Flat surface black 20" is standard. Flat surface chrome 20" is also available
- Desk, desk-to-counter and high heights

## r+ TECHNOLOGY

- Patented r+ combination of polyurethane and molded foam provides a comfortable seat
- Resists punctures, tears and virtually all spills; and cleans easily with bleach or ethanol
- Textured surface prevents slipping
- r+ properties: tear strength of 17.7 kgF, puncture resistance of 9.9 kgF, stretch of 660%, abrasion resistance of 25,000 and a Ross Flex rating of 150,000 flexes

## ESD

Cramer ESD chairs are engineered to safely ground static, protecting sensitive equipment before discharge can do damage.

- Certified electrostatic discharge protection from top to floor
- ESD-safe casters or glides
- Polyurethane seat covers for cleanable, static-safe durability
- Flat surface chrome footing is standard
- 27.5" polished aluminum base
- Chrome cylinder standard



ESD MODEL

## HOW TO CHOOSE THE MODEL

WORK SURFACE HEIGHT	CHAIR HEIGHT
29 - 32 IN	Desk
30 - 37 IN	Desk-to-Counter
33 - 42 IN	High

# Fusion r+

cramer

## PRICING

CHAIR HEIGHT	ADJUSTMENT MECHANISM	FUSION r+		ESD Fusion r+	
		MODEL NUMBER	LIST PRICE	MODEL NUMBER	LIST PRICE
Desk	2-Way	RPMD2	\$797.50		
	4-Way	RPMD4	\$885.50	RPMD4256Q	\$1,138.50
	7-Way	RPMD7	\$1,058.75		
Desk-to-Counter	2-Way	RPML2	\$929.50		
	4-Way	RPML4	\$1,017.50		
High	2-Way	RPMH2	\$902.00		
	4-Way	RPMH4	\$987.25	RPMH4256Q	\$1,237.50

2 Way - Seat Height, Back Depth  
 4 Way - Seat Height, Back Height, Back Angle, Seat Angle  
 7 Way - Seat Height, Back Height, Back Angle, Seat Angle, Chair Tilt, Forward Tilt Limiter, Seat Depth

## DIMENSIONS

SEAT DIMENSIONS	WIDTH (X) DEPTH	20.00 IN (X) 19.25
SEAT HEIGHT	MIN-MAX	
	DESK	16.50 IN - 21.50 IN
	DESK TO COUNTER	17.75 IN - 25.00 IN
	HIGH	22.00 IN - 32.00 IN
BACK DIMENSIONS	WIDTH (X) HEIGHT	16.75 IN - 15.00 IN
BASE DIMENSIONS	DIAMETER	26.75 IN
ARMPAD HEIGHT ABOVE SEAT	MIN - MAX	5.25 IN - 9.00 IN
DISTANCE BETWEEN ARMPADS	MIN - MAX	17.75 IN - 21.00 IN
WEIGHT	DESK	32 LBS
	DESK TO COUNTER	39 LBS
	HIGH	39 LBS
	ARMS	10 LBS



## OPTIONS

ORDER CODE	CATEGORY	LIST PRICE
<b>r+ COLOR OPTIONS</b>		
282	grey .....	
262	sky .....	
252	black .....	
256	black (ESD only).....	
<b>CASTERS</b>		
2	multi-surface dual wheel.....	standard**
3	non-rolling glide.....	n/c
9	weight activated breaks when seated .....	\$88.00 (not available for ESD models)
10	hard surface single wheel with 3" diameter .....	\$38.50 (not available for ESD models)
<b>ARMS</b>		
B	adjustable arms .....	\$112.75
T	articulating arms.....	\$143.00 (not available for ESD models)
<b>FOOTRINGS</b>		
	flat surface black footing.....	standard**
X	flat surface chrome footing (20").....	\$22.00 **on desk-to-counter and high height models only

\*\*Standard casters and footings included unless different options are requested.

## HOW TO ORDER

MODEL NUMBER	TEXTILE CODE	AVAILABLE OPTIONS CODE
<input type="text"/>	<input type="text"/>	<input type="text"/>

# Fusion Round Stool



The Fusion Round Stool offers a wider arc of movement, still with flexible ease and comfort. This model is versatile and comes in our r+™ technology.



## FEATURES

- Three seat heights
- Contoured foam seat ensures 24-hour comfort
- Hand activated height adjustment
- High performance twist-lock footring with 20" diameter on desk-to-counter and high heights only
- Supports up to 300 lbs
- 12-Year, Three-Shift Warranty
- SCS Indoor Advantage Gold Certification and may help contribute toward LEED certification
- ISO Class 5 Cleanroom

## CONSTRUCTION

- 16-gauge steel seat pan
- 25" fiberglass-reinforced nylon base
- Heat-bonded powder coat finish
- Class 4 pneumatic cylinder

## OPTIONS

- Casters: multi-surface dual wheel is standard. A variety of other casters are also available
- Desk, desk-to-counter, and high heights

## r+ TECHNOLOGY

- Patented Rhino Plus combination of polyurethane and molded foam provides a comfortable seat
- Resists punctures, tears and virtually all spills; and cleans easily with bleach or ethanol
- Textured surface prevents slipping
- r+ properties: tear strength of 17.7 kgF, puncture resistance of 9.9 kgF, stretch of 660%, abrasion resistance of 25,000 and a Ross Flex rating of 150,000 flexes

## HOW TO CHOOSE THE MODEL

WORK SURFACE HEIGHT	CHAIR HEIGHT
29 - 32 IN	Desk
30 - 37 IN	Desk-to-Counter
33 - 42 IN	High

ESD MODEL

# Fusion Round Stool r+

cramer

## PRICING

FUSION ROUND STOOL r+		
CHAIR HEIGHT	MODEL NUMBER	LIST PRICE
Desk	RP0D1	\$473.00
Desk-to-Counter	RP0L1	\$572.00
High	RP0H1	\$544.50

r+ Color Options - 252 Black, 262 Sky, 282 Graphite



## DIMENSIONS

SEAT DIMENSIONS	WIDTH (X) DEPTH	20.00 IN (X) 19.25
SEAT HEIGHT	MIN-MAX	
	DESK	15.50 IN - 20.75 IN
	DESK TO COUNTER	16.75 IN - 24.00 IN
	HIGH	21.00 IN - 31.00 IN
BACK DIMENSIONS	WIDTH (X) HEIGHT	17.00 IN - 12.00 IN
BASE DIMENSIONS	DIAMETER	25 IN
WEIGHT	DESK	16 LBS
	DESK TO COUNTER	23 LBS
	HIGH	23 LBS
	BACK	8 LBS

## OPTIONS

ORDER CODE	CATEGORY	LIST PRICE
<b>r+ COLOR OPTIONS</b>		
282	grey .....	
262	sky .....	
252	black .....	
<b>CASTERS</b>		
2	multi-surface dual wheel.....	standard**
3	non-rolling glide.....	n/c
9	weight activated brakes when seated.....	\$88.00
10	hard surface single wheel with 3" diameter.....	\$38.50
<b>FOOTRINGS</b>		
	flat black footing.....	standard**
X	flat surface chrome footing (20").....	\$22.00

\*\*Standard casters and footings included unless different options are requested.



## HOW TO ORDER

MODEL NUMBER	TEXTILE CODE	AVAILABLE OPTIONS CODE
<input type="text"/>	<input type="text"/>	<input type="text"/>

# Adjustments

## ADJUST TO TASK FOR PRODUCTIVITY AND ERGONOMICS

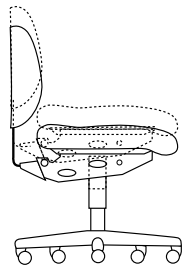

**SEAT HEIGHT**  
ALL MECHANISMS  
Chair can be raised or lowered to numerous heights.

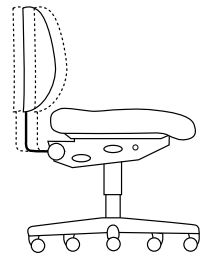

**BACK DEPTH**  
2 WAY  
Backrest slides in and out and locks in numerous positions to allow additional room between the seat cushion and the backrest.

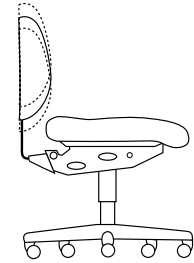

**BACK HEIGHT**  
4 / 7 WAY  
Backrest slides up and down and locks in place through a locking wheel adjustment (also known as lumbar adjustment).

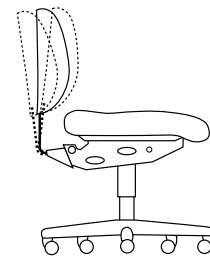

**BACK ANGLE**  
4 / 7 WAY  
Backrest pivots forward and back, independent of seat angle. Locks at desired angle.

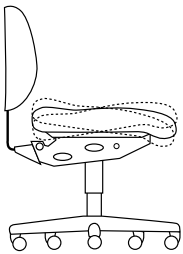

**SEAT ANGLE**  
4 / 7 WAY  
Seat tilts forward and back. Locks at desired angle.

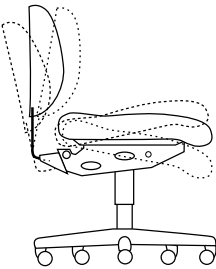

**CHAIR TILT**  
7 WAY  
Chair (seat and back together) tilts forward and back. Allows chair to rock when seat angle is unlocked.

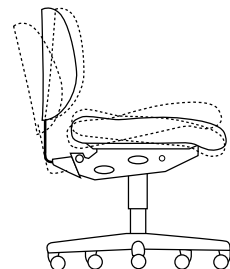

**FORWARD TILT LIMITER**  
7 WAY  
When engaged, prevents full forward tilt and/or rocking. Convenient function for many tasks.

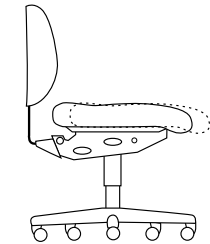

**SEAT SLIDER**  
7 WAY  
Seat slides forward and back. Locks in desired position. Important way to adjust leg support for different sized users.

## To find the right chair height:

Measure the work surface height and subtract the 11 inch ergo factor = ideal average seat height

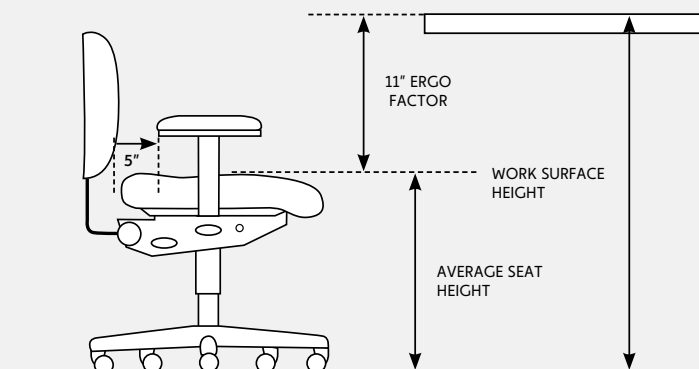

# Casters

## CASTER OPTION DETAILS

Our Multi-Surface Dual Wheel caster is our standard caster. Other options are available for unique work environments.

AVAILABLE FOR ESD	CASTER DESCRIPTION	APPLICATION
YES	2. Multi-surface dual wheel	General purpose for hard surface and carpet
YES	3. Universal glide	This is a pad, not a wheel, use on any floor surface
YES	9. Weight-activated locks when seated caster	Caster will roll only when you are not seated
NO	10. Hard surface with 3" diameter	General purpose for hard surface, especially concrete (adds 1" to height)

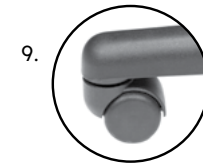
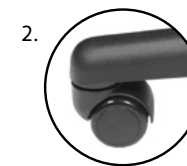

## CRAMER WARRANTY



THREE-SHIFT  
WARRANTY

Labor charges for repairs performed outside of the factory, or for installation of replacement parts, is the responsibility of the purchaser, unless specifically approved in advance by Cramer.

Standard textiles, foam assembly and arm pads are warranted for three (3) years. The polyurethane skin and foam assembly on r+™ and i+™ products are warranted for five (5) years.

This warranty applies only to products used under normal conditions by the original purchaser. Warranties do not apply to damage from neglect, abuse, normal wear and tear, or to products that have been modified by the user. Cramer supplied replacement parts must be used to retain warranty coverage.

Cramer's liability is limited to repair or replacement, at Cramer's option, and cannot exceed the original invoice price. All labor charges must be pre-approved. Cramer is not liable for incidental or consequential damage arising in connection with the sale, use or serviceability of Cramer products. Repairs or replacements do not carry a warranty or extend the original warranty period.

For warranty claims, contact Customer Care at 1.800.366.6700. For the fastest service, have the following information ready: SO#, explanation of the issue, pictures, contact info and mailing address for replacement parts. This helps us determine when the chair was manufactured and other specific details necessary to respond to your questions. THIS WARRANTY IS IN LIEU OF OTHER WARRANTIES EXPRESSLY STATED OR IMPLIED.

For questions about our warranty, please email or call Customer Care at: support@cramerinc.com / 1.800.366.6700.

For warranty claims, contact Customer Care at support@cramerinc.com or 1.800.366.6700. For the fastest service, have the following information ready:

- 1.) CO# / SO#
- 2.) Explanation of the issue
- 3.) Pictures
- 4.) Contact info (name, phone, email)
- 5.) Mailing address for replacement parts

This warranty is in lieu of other warranties expressly stated or implied.

## Warranty Claim Requirements

## CRAMER ESD

### CRAMER CHAIRS CONTROL STATIC ELECTRICITY

Cramer ESD chairs are designed to meet the ESD Association standard test method for the Protection of Electrostatic Discharge Susceptible Items-Seating-Restive Measurement standard ESD STM 12.1-2019. This includes testing of the seat, backrest, rear of backrest, armrest (if applicable) and base. Models require an upholstered outer back option to comply with ESD standard STM12.1-2019.

The chair frame, from the back to the base, is electrically conductive to ensure static charges will be dissipated through the upholstery and the chair frame to floor grounds. Conductive casters and glides available in black only.

Upholstery is ESD vinyl or conductive R+ material specially woven with conductive fibers and backcoated with a conductive medium. Special conductive materials are installed in contact with the upholstery materials and the chair frame, ensuring immediate dissipation of static charges. Prior to shipment, Cramer tests each ESD chair for conductive quality.

ESD option includes chrome footring, polished aluminum base, chrome barrel, and upholstered outer back. Limited caster options include: #2 dual wheel caster or #3 glide.

## CRAMER FIRE CODE

### TB 117

Cramer chairs pass TB117\*. Components used in seating, such as foam and fabric are tested individually for flammability characteristics. This is a minimum standard for all furniture offered for sale in California. Cramer is not responsible for Customers Own Material (COM) upholstery fire code compliance.

\*Does not apply to Helix.

## CRAMER CLEANROOM

Cramer cleanroom chairs are designed for minimal particulate contribution as certified by tests conducted in accordance with ASTM F25-68, ISO 14644-2-2015 and SAE ARP734A. Air introduced into the test chamber is filtered through 99.99% effective, .5 micron filters. The test chamber is subject to simulated usage by depressing the cushions while a discrete-particle counter records the particulate count. Cramer offers Cleanroom seating products manufactured to meet FED STD 209E (ISO/TC209) in Class 10 and 100 / ISO 14644-1-2015 Class 4 and 5.

**ISO Class 3 (Fed Std 209e Class 1)**  
Citrus

**ISO Class 4 (Fed Std 209e Class 10)**  
Helix, Rhino Basic Sit / Stand (will not meet Class 10 if arm option "B" or "T" is ordered)

**ISO Class 5 (Fed Std 209e Class 100)**  
Fusion, Fusion R+, Fusion Round Stool, Fusion Round Stool R+

All exposed metal frame components are chrome plated or powder epoxy coated. To prevent present and future contamination, all footrings are sealed with MIG-welds. Seat heights are achieved by sealed, contaminate-free pneumatic cylinders.

## CRAMER AND THE ENVIRONMENT

Corporate and environmental stewardship are priorities at Cramer. It is part of our mission statement, evident in every chair and stool in our seating product line, and recognized by SCS Gold certifications.

### ENVIRONMENTAL STEWARDSHIP

We are committed to conduct business in a manner that protects our natural environment and embraces the principals of sustainability and environmental stewardship. We continue to invest in better materials, methods and manufacturing practices to enhance sustainability and care of the environment.

### SCS GOLD CERTIFICATION

The entire line of Cramer seating products is SCS Indoor Advantage™ Gold Certified in North America. The criteria for achieving this industry environmental standard are established by BIFMA and US Green Building Council.





## Specialized Seating for Labs and Technical Spaces

## CUSTOMER CARE

1.800.366.6700

[support@cramerinc.com](mailto:support@cramerinc.com)

[sales@cramerinc.com](mailto:sales@cramerinc.com)

[orders@cramerinc.com](mailto:orders@cramerinc.com)

# cramer

Cramer, LLC. 1523 Grand Boulevard, Kansas City, MO 64108  
customer care 1.800.366.6700 fax 1.800.607.2821 [www.cramerinc.com](http://www.cramerinc.com)