

Parts List

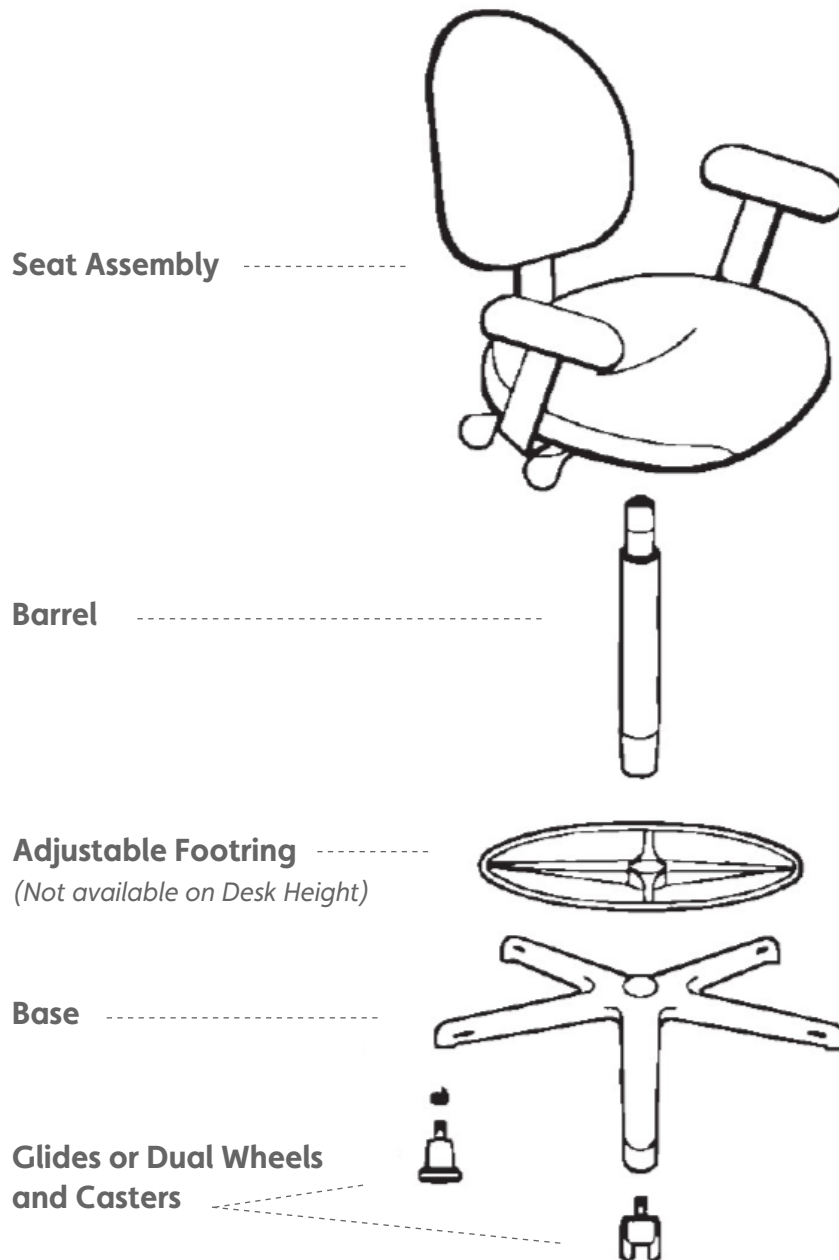

STEP 1

Turn base up-side down.

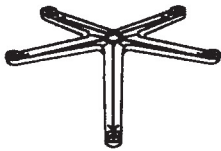

STEP 2

Firmly push a glide/caster into each of the holes at the end of the 5 base legs.

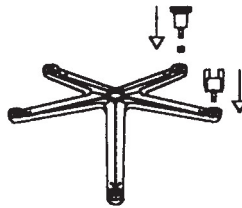

STEP 3

Turn the base right side up. Firmly insert the barrel into the base.

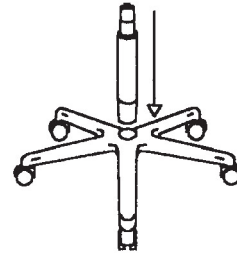

STEP 4

ONLY FOR CHAIRS WITH ADJUSTABLE FOOTRING OPTION. Place the adjustable footring on the barrel and tighten it. It can be adjusted for height after the chair has been fully assembled.

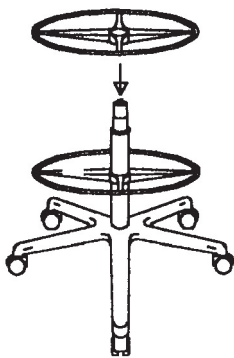

STEP 5

Place the seat on the barrel. The easiest and safest way to do this is to turn the chair upside down and push the base/barrel assembly into the hole in the chair mechanism. For a standard size chair, hold the barrel cover on the barrel as you insert it in the assembly. Be sure to lodge the parts together securely.

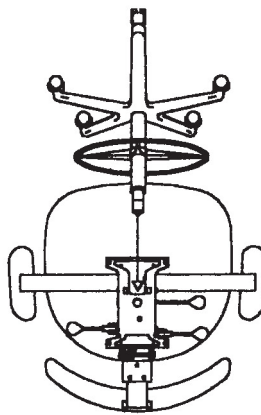

STEP 6

Gently roll your chair right side up. If necessary, adjust the footring to a comfortable height. Check to make sure all parts are fully and securely assembled.

