

HelixTM

Assembly Instructions



Contents



Chair Assembly

3 - 9



Cleaning

11



No tools required.

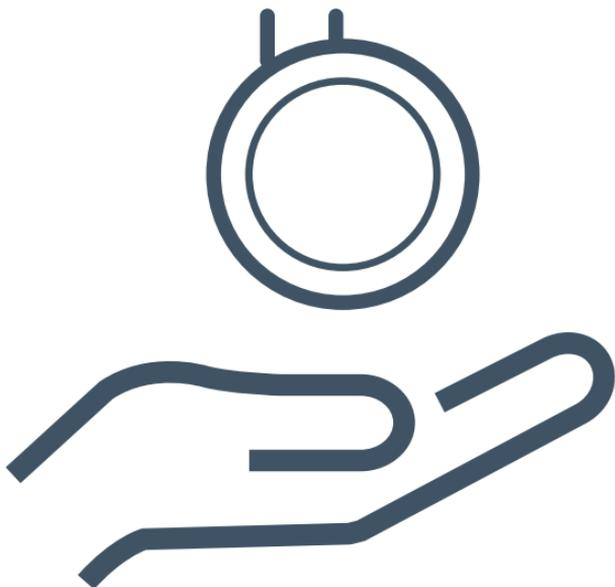

Chair Assembly

1

Insert casters into base.

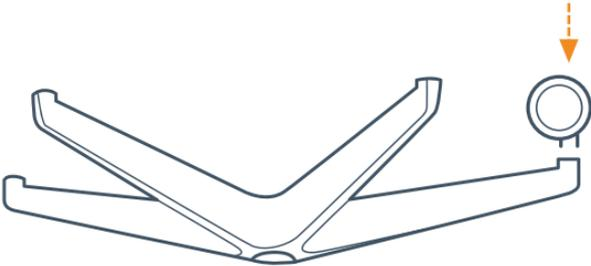

2

Insert cylinder in base.

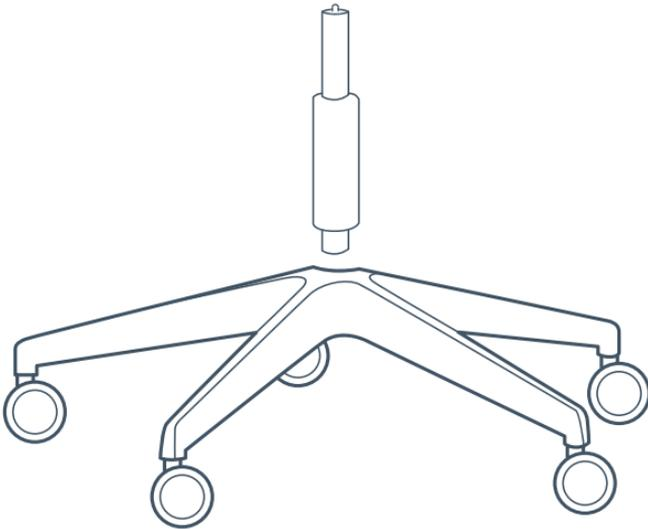

3

Attach optional foot ring. Once foot ring is at desired height, turn counterclockwise to tighten.

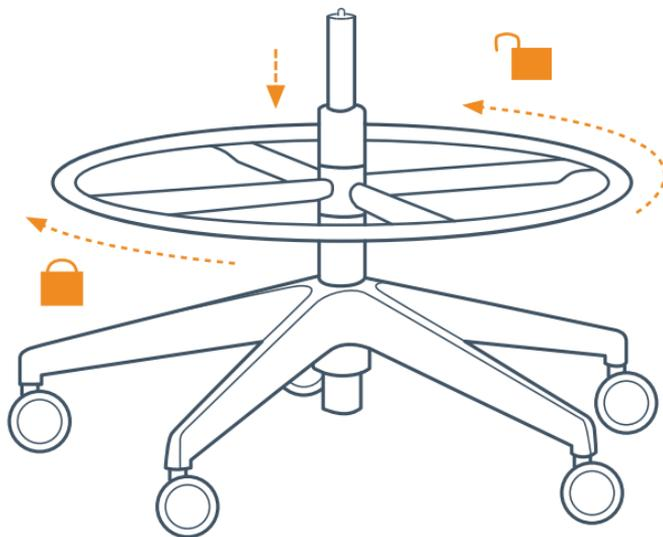

4

**Connect chair assembly to cylinder.
Then sit in seat to securely attach and
adjust height.**

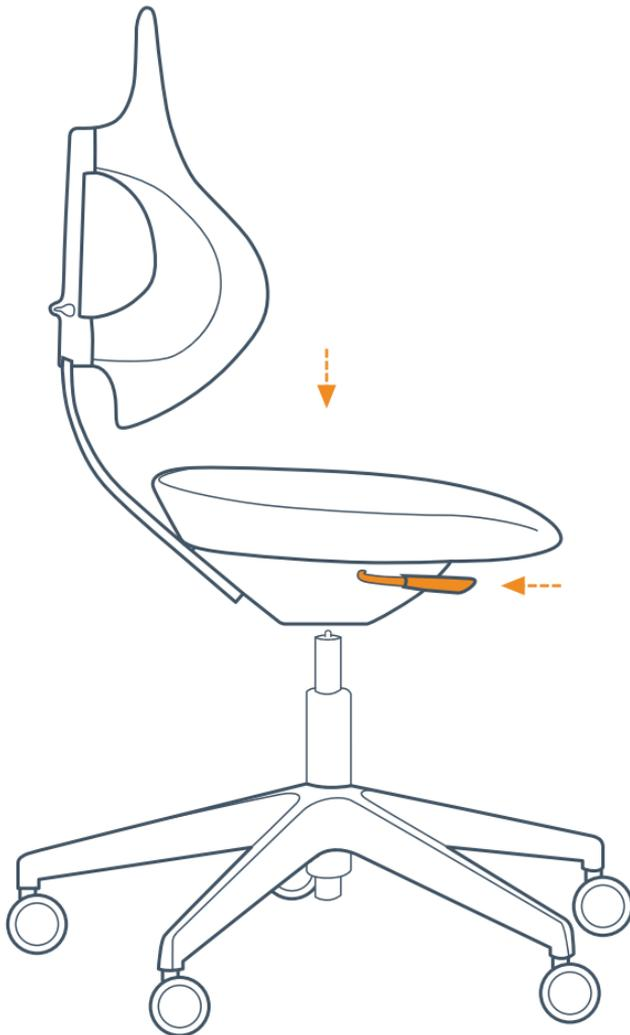

5

Ready for use!

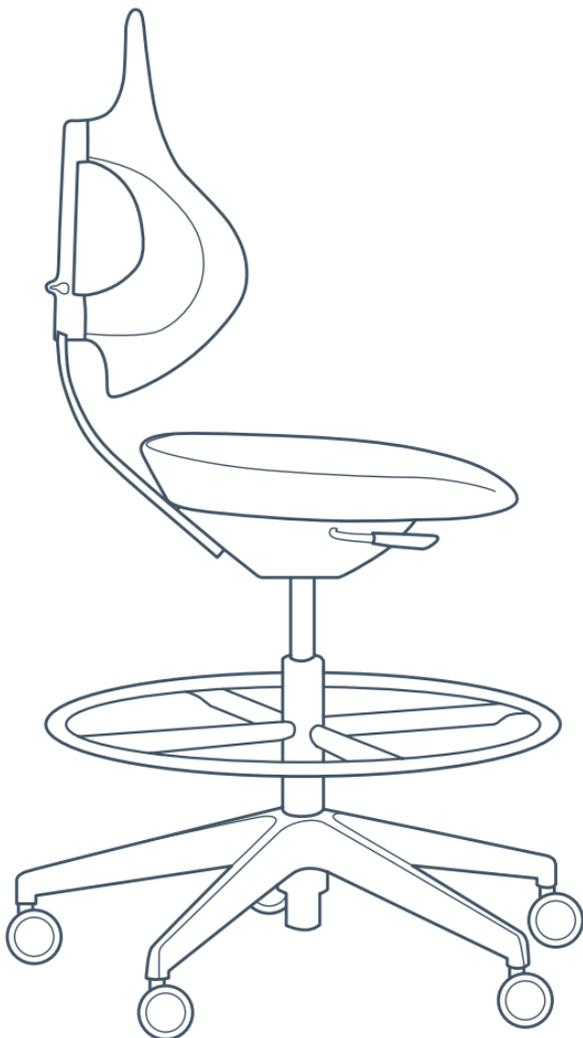



Model #HXDU5



Model #HXHU5



Model #HXDU4
*shown with option A, arms



Model #HXHU4
*shown with option A, arms





Cleaning

Helix complies with BIFMA HCF 8.1 - 2014 standards for cleaning products.



1523 Grand Blvd.
Kansas City, MO 64108

800.366.6700
support@cramerinc.com

cramerinc.com

HX7004